

APPLICATION:

PRODUCT NAME:  
SINGLE DECK DUAL CONTROL VALVE

JOB NAME:

SPECIAL CONFIGURATION  
 CHECK BASE MODEL AND OPTIONS

QUANTITY:

ITEM NO.

MODEL:  
 13080

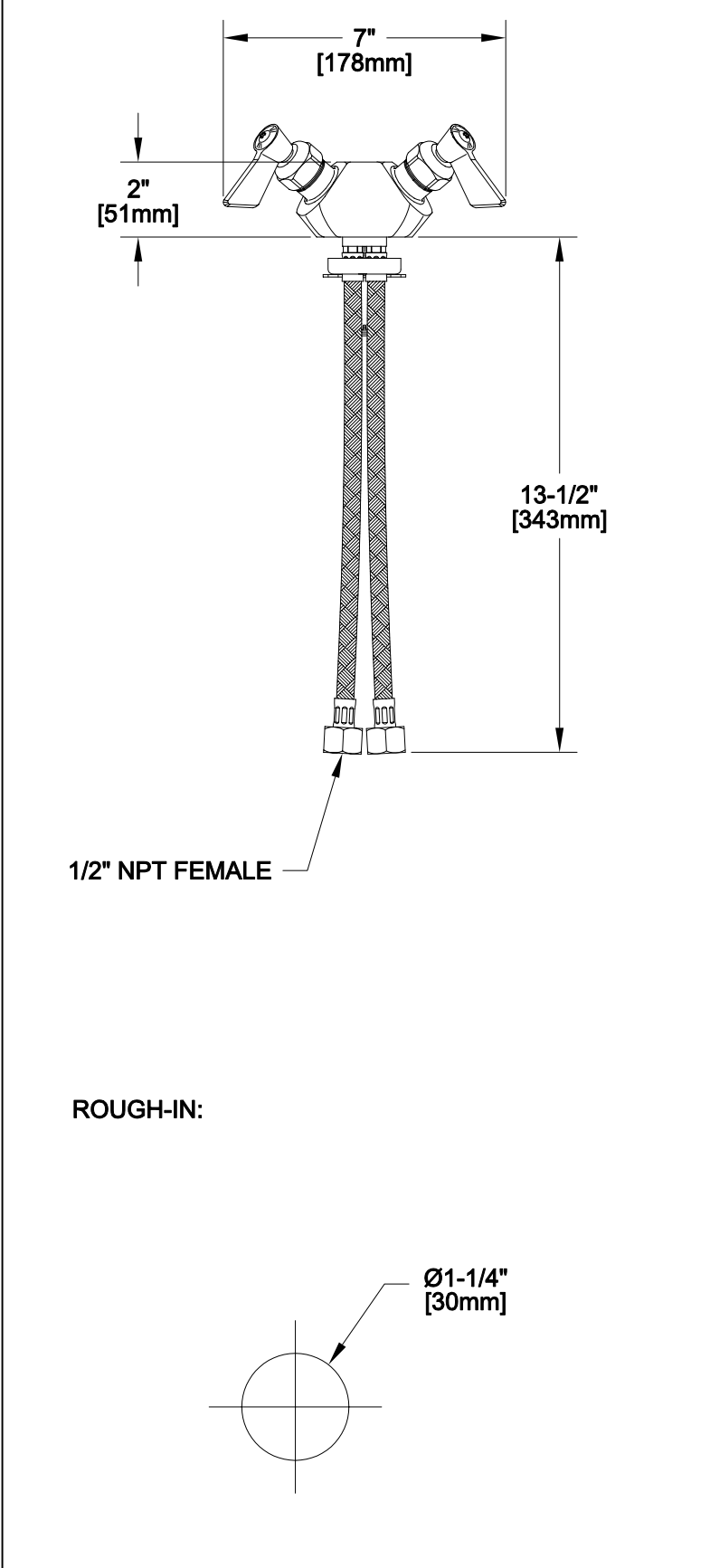

OPTIONS OR MODIFICATIONS:  
 SUPPLY LINES (24" OR 36") CIRCLE LENGTH  
 HANDLES (CROSS OR WRIST) CIRCLE STYLE  
 VANDAL RESISTANT KIT  
 OTHER \_\_\_\_\_

FEATURES

CONTROL VALVE

- \* 3/8" FEMALE NPT OUTLET
- \* INTERNAL SPRING LOADED CHECK VALVES
- \* HOT SIDE STEM - RIGHT HAND
- \* COLD SIDE STEM - LEFT HAND
- \* SWIVELLING SEAT DISKS
- \* STAINLESS STEEL SEATS
- \* STAINLESS STEEL SEAT SCREWS
- \* STAINLESS STEEL HANDLE SCREWS
- \* FLEXIBLE INLET HOSES

SYSTEM LIMITS

- \* TEMP: 40°F MIN. TO 140°F MAX.
- \* PRESSURE: 200 PSI MAX. STATIC

SHIPPING WEIGHT

- \* 5.0 LBS

ANSI/A112.18.1M

**FISHER**  
 FISHER MANUFACTURING COMPANY  
 TOLL FREE: 800-421-6162 - FAX: 800-832-8238  
 information@fisher-mfg.com - www.fisher-mfg.com